

Important instructions for Timber to Metal screws

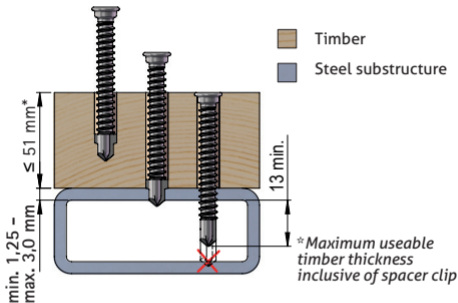

AnchorMark



Instructions for use

Drive in the fastener with high to maximum speed **using a cordless drill or electric drill**. As soon as you hit the metal substructure, reduce speed and increase the pressure slightly. Make sure you don't overdrive the fastener by stopping as soon as the screw head is levelled with the surface.

Only to be used with a drill driver (cordless or corded) / DO NOT USE AN IMPACT DRIVER